

Main Feature

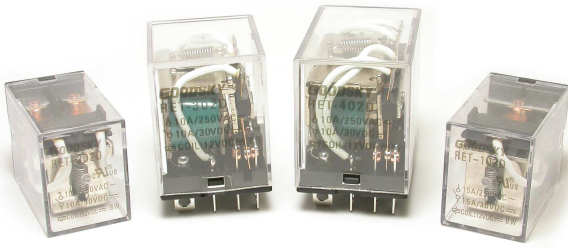

1. 1 Pole to 4-Poles versions available with switching current at 15A (1 Pole) and 10A (2-4 Poles).
2. Printed Circuit Board Terminal, Plug-in Terminal and Flanged Case are designed for easy mounting.
3. Both AC and DC coil available.
4. Low coil power consumption with high response time.
5. High reliability and long life with better vibration and shock resistance.
6. 1/3 HP on RET 2 Poles series is certified by UL.
7. Touch Button and LED version available.

Contact Rating

Load Type	RET-1P	RET-2P	RET-3P	RET-4P
Rated Load (Resistive)	15A 250VAC	10A 250VAC	10A 250VAC	10A 250VAC
	15A 30VDC	10A 30VDC	10A 30VDC	10A 30VDC
Contact Capacity	-	1/3 HP 250VAC	-	-
Rated Carrying Current	15A	10A	10A	10A
Max. Allowable Voltage	AC 250V	AC 250V	AC 250V	AC 250V
	DC 110V	DC 110V	DC 110V	DC 110V
Max. Allowable Current	15A	10A	10A	10A
Max. Allowable Power Force	1,700VA	1,100VA	1,100VA	1,100VA
	360W	240W	240W	240W
Contact Material	Ag Alloy	Ag Alloy	Ag Alloy	Ag Alloy
Contact Form	SPDT, SPST	DPDT, DPST	3PDT, 3PST	4PDT, 4PST

Application

Vending Machine, Cooking Appliances, Office Machine, Domestic Appliances, Control Equipment, etc.

Performance (at Initial Value)

- Contact Resistance 100 mΩ Max. @1A,6VDC
- Operate Time..... 25 mSec. Max.
- Release Time 25 mSec. Max.
- Dielectric Strength:
 - Between Coil & Contact..... 1,500VAC at 50/60 Hz for one minute
 - Between Contacts 1,000VAC at 50/60 Hz for one minute
- Surge Strength..... 3,000V (between Coil & Contact 1.2x50μSec.)
- Insulation Resistance 100 MegaΩ Min. at 500VDC
- Max. On/Off Switching:
 - Electrical..... 6 Cycles per Minute
 - Mechanical 300 Cycles per Minute
- Temperature Range..... -25~+55°C
- Humidity Range..... 45~85% RH.
- Coil Temperature Rise..... 60°C Max.

- Vibration:
 - Endurance..... 10 to 55 Hz dual amplitude width 1.5mm
 - Error Operation 10 to 55 Hz dual amplitude width 1.5mm
- Shock:
 - Endurance 1,000 m/S²
 - Error Operation 100 m/S²
- Life Expectancy:
 - Mechanical 10⁷ Operations at No Load condition
 - Electrical 10⁵ Operations at Rated Resistive Load
- Weight.....
 - 1-2P :About 35 g
 - 3P :About 53.2g
 - 4P :About 66.5g

Safety Standard & File Number

- UL & C-UL (1-pole & 2-pole).....E141060

Coil Specification (at 20°C)

Coil Sensitivity	Coil Voltage Code	Nominal Voltage (VAC/VDC)	Nominal Current (mA)		Coil Resistance ($\Omega \pm 10\%$)	Power Consumption		Pull-In Voltage (VDC)	Drop-Out Voltage (VDC)	Max.Allowable Voltage (VDC)
			50 Hz	60 Hz		50Hz	60Hz			
RET 1-P & 2-P AC Coil	01	6	282.7	214.3	10	1.7VA	1.29VA	80% Maximum	30% Minimum	110%
	02	12	106.2	94.9	40	1.27VA	1.14VA			
	03	24	52.8	45.5	160	1.27VA	1.09VA			
	04	48	23.7	20.0	600	1.1VA	0.96VA			
	05	110	12.5	10.3	3,400	1.37VA	1.13VA			
	06	120	16.8	14.3	3,400	2.01VA	1.72VA			
	07	220	6.2	5.1	13,600	1.36VA	1.12VA			
	08	240	7.2	5.9	13,600	1.74VA	1.41VA			
	09	230	7.0	5.7	13,600	1.61VA	1.31VA			
RET 3-P AC Coil	01	6	310	270	6.7	Abt. 1.6 to 2.0VA (60 Hz)	80% Maximum	30% Minimum	110%	
	02	12	159	134	24					
	03	24	80	67	100					
	04	48	38	33	410					
	05	110	16	13.7	2,300					
	06	120	15.4	13.2	2,300					
	07/08	220/240	10	8.5	8,650					
RET 4-P AC Coil	01	6	386	330	5	Abt. 1.95 to 2.5 VA (60 Hz)	80% Maximum	30% Minimum	110%	
	02	12	199	170	20					
	03	24	93.6	80	78					
	04	48	46.8	40	350					
	05	110	25.5	21.8	1,600					
	06	120	24.5	21	1,600					
	07/08	220/240	13.1	11.2	6,700					
RET 1-P & 2-P DC Coil	01	6	150		40	Abt. 0.9 W	80% Maximum	10% Minimum	110%	
	02	12	75		160					
	03	24	36.9		650					
	04	48	18.5		2,600					
	05	110	10		11,000					
	06	120	10		11,000					
	10	60	15		4,000					
RET 3-P DC Coil	01	6	234	25.7		Abt. 1.4 W	80% Maximum	10% Minimum	110%	
	02	12	112	107						
	03	24	58.6	410						
	04	48	28.2	1,700						
	05	110	13	8,500						
	06	120	14.1	8,500						
RET 4-P DC Coil	01	6	240	25		Abt. 1.5 W	80% Maximum	10% Minimum	110%	
	02	12	120	100						
	03	24	69	350						
	04	48	30	1,600						
	05	110	15.9	6,900						
	06	120	17.4	6,900						

RET

Ordering Information

RET - 2	01	D	M	P	F	L	T	
								Touch Button: Nil: Standard Relay T: With Touch Button Selection
								LED: Nil: Standard Relay L: With LED Selection (Use Polarity LED) Z: Coil Parallel with Diode & the Positive Pole "+" On #8(RET-1P,RET-2P) \ #11(RET-3P) \ #14(RET-4P) Y: Coil Parallel with Diode & the Negative Pole "-" On #8(RET-1P,RET-2P) \ #11(RET-3P) \ #14(RET-4P) X: Coil Parallel with Diode + LED & the Positive Pole "+" On #8(RET-1P,RET-2P) \ #11(RET-3P) \ #14(RET-4P) V: Coil Parallel with Diode + LED & the Negative Pole "-" On #8(RET-1P,RET-2P) \ #11(RET-3P) \ #14(RET-4P)
								Case Type: Nil: Standard Square Shape F: Flanged Case
								Terminal Type: Nil: Solder Lug Terminal P: PC Board Terminal
								Contact Form: Nil: Form C M: Form A B: Form B
								Coil Type: D: Standard DC A: Standard AC
								Coil Code: 01: 6V, 02: 12V, 03: 24V, 04: 48V, 05: 110V, 06: 120V, 07: 220V, 08: 240V, 09: 230V, 10: 60V
								Number of Pole: 1: 1 Pole 2: 2 Poles 3: 3 Poles 4: 4 Poles
								Type: RET

Classification

Model	RET							
	AC				DC			
Coil Type								
Number Of Poles	1C / 1A / 1B	2C / 2A / 2B	3C / 3A / 3B	4C / 4A / 4B	1C / 1A / 1B	2C / 2A / 2B	3C / 3A / 3B	4C / 4A / 4B
Contact Form	RET-1/2□□A/AM/AB		RET-3/4□□A/AM/AB		RET-1/2□□A/AM/AB		RET-3/4□□A/AM/AB	
Terminal Type	RET-1/2□□A/AM/AB RET-1/2□□AP/AMP/ABP		RET-3/4□□A/AM/AB RET-3/4□□AP/AMP/ABP		RET-1/2□□A/AM/AB RET-1/2□□AP/AMP/ABP		RET-3/4□□A/AM/AB RET-3/4□□AP/AMP/ABP	
Case Type	RET-1/2□□A/AM/AB RET-1/2□□AF/AMF/ABF		NIL		RET-1/2□□D/DM/DB RET-1/2□□DF/DMF/DBF		NIL	
LED	RET-1/2□□AL/AML/ABL RET-1/2□□APL/AMPL/ABPL RET-1/2□□AFL/AMFL/ABFL		NIL		RET-1/2□□DL/DML/DBL RET-1/2□□DPL/DMPL/BPL RET-1/2□□DFL/DMFL/DBFL		NIL	
Touch Button	RET-1/2□□AT/AMT/ABT RET-1/2□□ APLT/AMPLT/ABPLT RET-1/2□□ALT/AMLT/ABLT RET-1/2□□ AFLT/AMFLT/ABFLT		NIL		RET-1/2□□DT/DMT/DBT RET-1/2□□ DPLT/DMPLT/DBPLT RET-1/2□□DLT/DMLT/DBLT RET-1/2□□ DFLT/DMFLT/DBFLT		NIL	

Dimension ($\leq 5\text{mm} \pm 0.2\text{mm}$, $> 5\text{mm} \pm 0.3\text{mm}$, the tolerance of PCB thru hole: $+0.1\text{mm}$)

RET-1-P

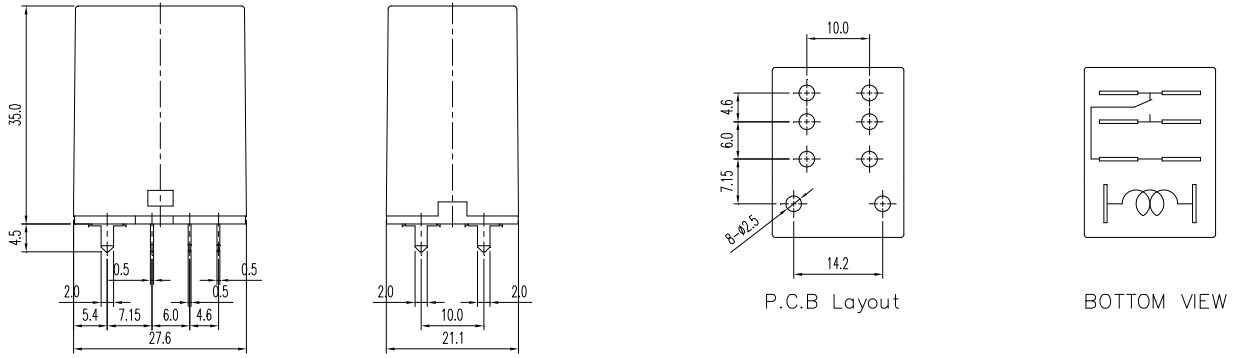

RET-1

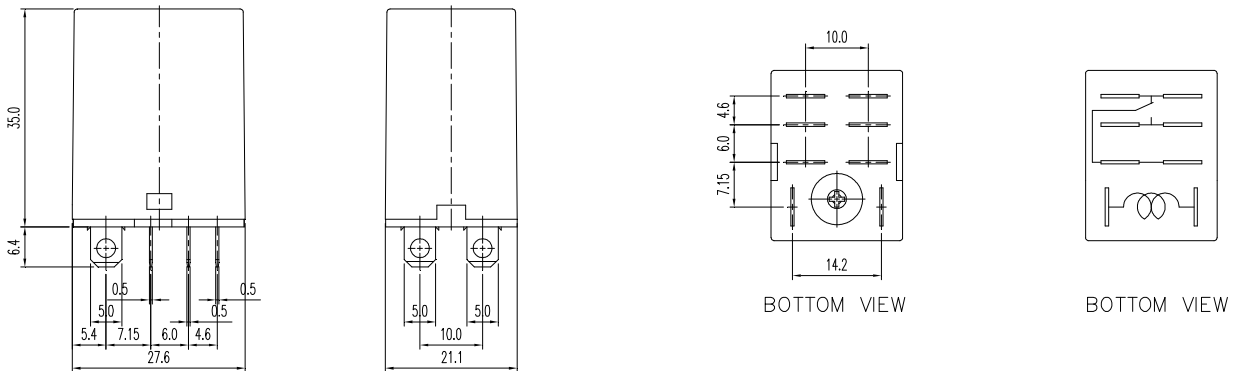

RET-1-F

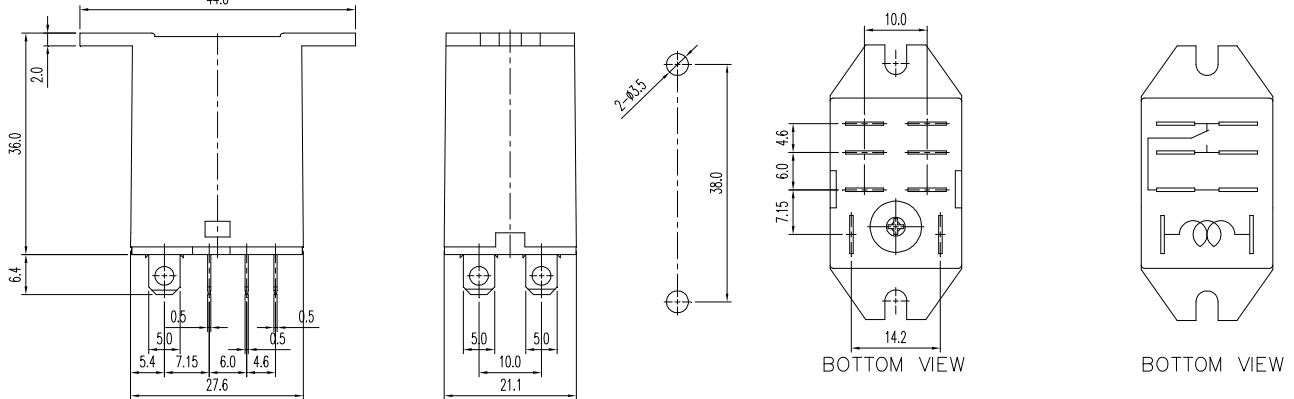

RET-2-P

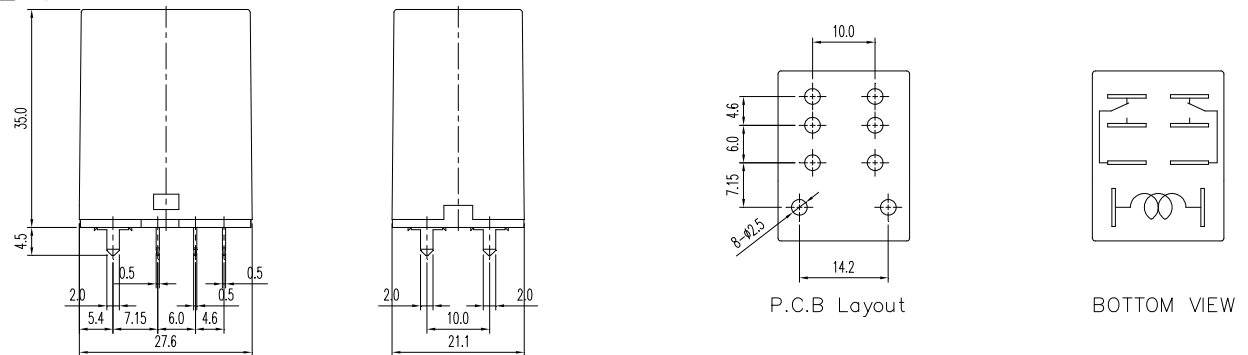

RET-2

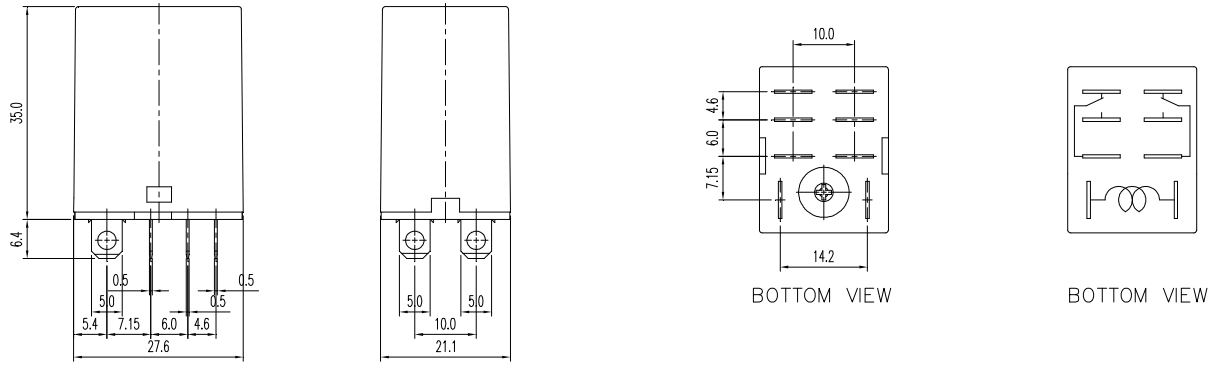

RET-2-F

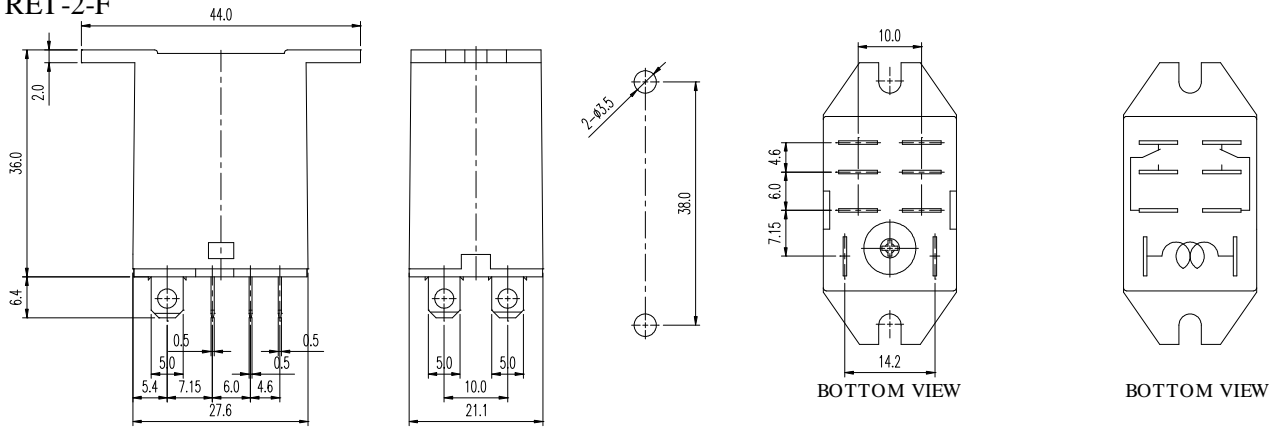

RET-3

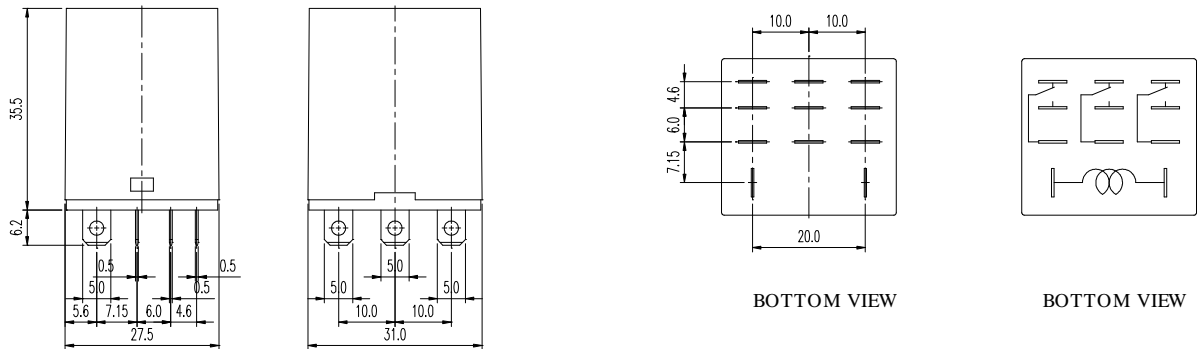

RET-4

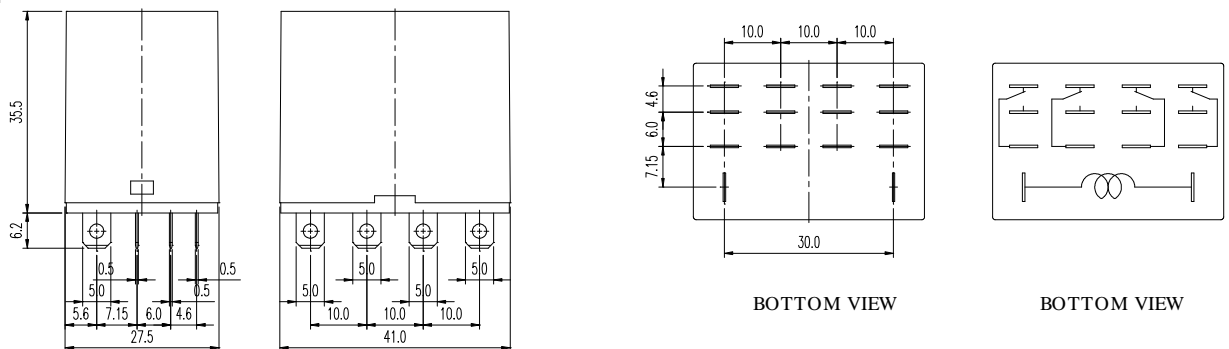

Accessories & Sockets

RET-1P/2P

- PTF-08ASee Page 175
- PTF-08AESee Page 175
- PT-08See Page 181
- PT-08-0See Page 181

RET-4P

- PTF-14A.....See Page 175
- PTF-14AE..... See Page 175

Wiring diagrams (Bottom view)

RET-1P					
RET-1□D□□□□L□	RET-1□D□□□□Z□	RET-1□D□□□□Y□	RET-1□D□□□□X□	RET-1□D□□□□V□	AC Coil Model With LED
RET-2P					
RET-2□D□□□□L□	RET-2□D□□□□Z□	RET-2□D□□□□Y□	RET-2□D□□□□X□	RET-2□D□□□□V□	AC Coil Model With LED
RET-3P					
RET-3□D□□□□L□	RET-3□D□□□□Z□	RET-3□D□□□□Y□	RET-3□D□□□□X□	RET-3□D□□□□V□	AC Coil Model With LED
RET-4P					
RET-4□D□□□□L□	RET-4□D□□□□Z□	RET-4□D□□□□Y□	RET-4□D□□□□X□	RET-4□D□□□□V□	AC Coil Model With LED