

Main Feature

1. SF: Flat formed type power relay rating 16A.
2. SFG: Flat formed type power relay with fasten terminals and PC board terminals.
3. Low power consumption 200mW.
4. Halogen Free series available.
5. Comply with RoHS and REACH regulations



Contact Rating

Load Type	SF (DM)	SFG (DM)
Rated Load (Resistive)	15A 125VAC	12A 125VAC
	10A 277VAC	10A 277VAC
	16A 250VAC (TUV)	TV-5 120VAC
	15A 24VDC (TUV)	10A 24VDC
Contact capacity	1/4HP 125/250VAC TV-5 120VAC	-
Rated Carrying Current	16A	12A
Max. Allowable Voltage	AC 277V	AC 277V
Max. Allowable Current	16A	12A
Max. Allowable Power Force	4,000VA	2,770VA
	360W	240W
Contact Material	Ag Alloy	Ag Alloy
Contact Form	SPST	SPST

Application

Domestic, Appliance, Office Machine, Air Conditioner, Controlling Equivalent, etc.

Performance (at Initial Value)

- Contact Resistance 100mΩ Max. @1A,6VDC
- Operate Time..... 20 mSec. Max.
- Release Time 10 mSec. Max.
- Dielectric Strength:
 - Between Coil & Contact..... 1,500VAC at 50/60 Hz for one minute
 - Between Contacts 1,000VAC at 50/60 Hz for one minute
- Surge Strength.....5,000V (between Coil & Contact 1.2x50μSec.)
- Insulation Resistance 100 MegaΩ Min. at 500VDC
- Max. On/Off Switching:
 - Electrical..... 6 Cycles per Minute
 - Mechanical 300 Cycles per Minute
- Temperature Range..... -40~+85°C
- Humidity Range 45~85% RH.
- Coil Temperature Rise 35°C Max.
- Vibration:
 - Endurance 10 to 55 Hz dual amplitude width 1.5mm
 - Error Operation..... 10 to 55 Hz dual amplitude width 1.5mm
- Shock:
 - Endurance 1,000 m/S²
 - Error Operation..... 100 m/S²
- Life Expectancy:
 - Mechanical 10⁷ Operations at No Load condition
 - Electrical 10⁴ Operations at Rated Resistive Load
- Weight About SF : 8.5 g
SFG : 9.0 g

Safety Standard & File Number

- SF: UL & C-UL..... E141060
TÜV..... R09956053
- SFG: NIL

Coil Specification (at 20°C)

Coil Sensitivity	Nominal Voltage (VDC)	Nominal Current (mA)	Coil Resistance ($\Omega \pm 10\%$)	Power Consumption (W)	Pull-In Voltage (VDC)	Drop-Out Voltage (VDC)	Maximum Allowable Voltage (VDC)
SF/SFG	5	40	125	Abt. 0.20	70% Maximum	5% Minimum	150%
	6	34	180				
	9	23	405				
	12	17	720				
	18	11	1,620				
	24	8.3	2,880				
	48	4.2	11,520	Abt. 0.56			
100	5.6	18,000					

Ordering Information

SF - SS - 1 12 D M

Contact Form: M: One Form A
Coil Type: D: Standard DC
Coil Voltage: 05: 5V, 06: 6V, 09: 9V, 12: 12V, 18: 18V, 24: 24V, 48: 48V, 100: 100V
Number of Pole: 1: One Pole
Type of Sealing: SS: RT II Flux Proofed
 SH: RT III Wash Tight
Type: SF
 SFG

Classification

Model	SF	SFG
Contact Form	1A	1A
Flux Proofed	SF-SS-1□□DM	SFG-SS-1□□DM
Wash Tight	SF-SH-1□□DM	SFG-SH-1□□DM

Dimension ($\leq 5\text{mm} \pm 0.2\text{mm}$, $> 5\text{mm} \pm 0.3\text{mm}$, the tolerance of PCB thru hole: $+0.1\text{mm}$)

SF-SS/SH

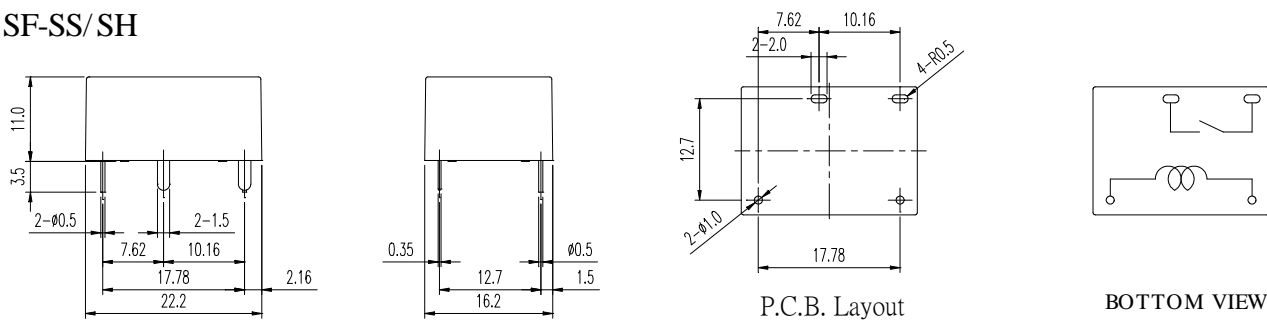

SFG-SS

